

PLAN

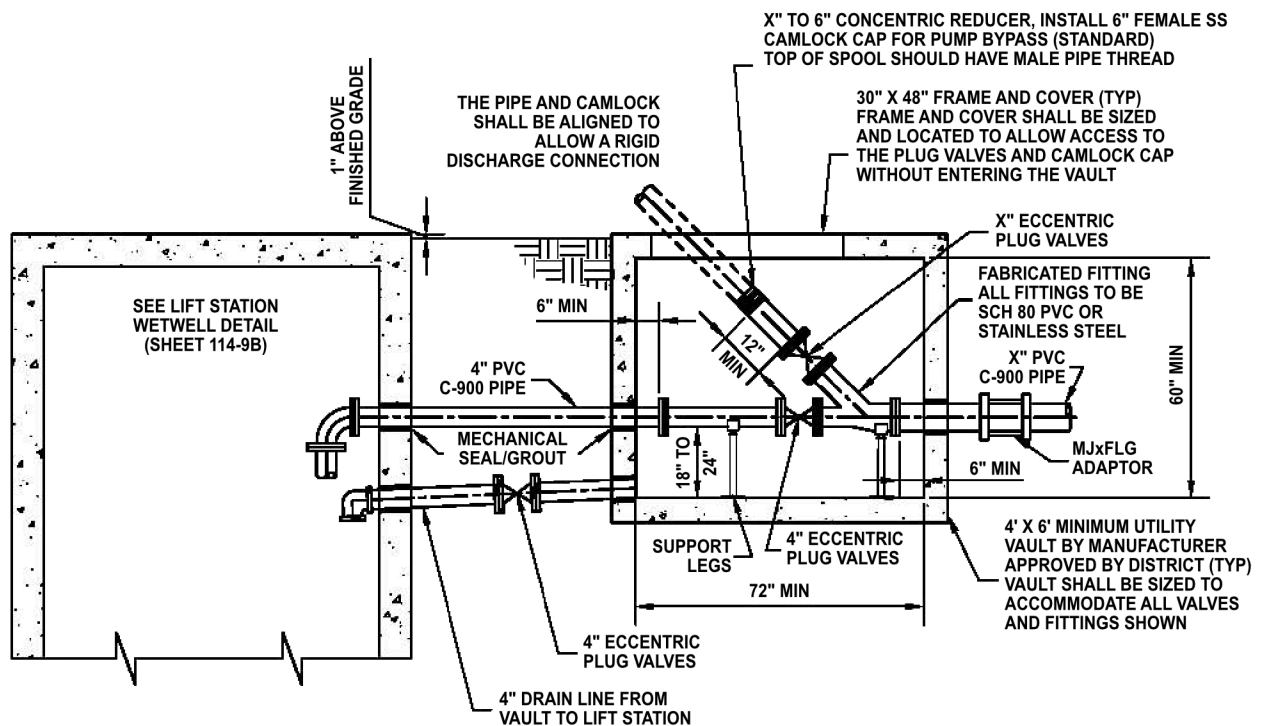

SECTION

NOTES:

- 1 - MECHANICAL SEALS AND GROUT SHALL BE USED FOR ALL VALVE VAULT PERFORATIONS.
- 2 - EXHAUST VENTS SHALL NOT BE PERMITTED ON LIFT STATION FACILITIES.
- 3 - INTERIOR VALVE VAULT COMPONENTS SHALL BE PROPERLY PAINTED.
- 4 - ACCESS FRAME AND COVER SHALL BE APPROVED BY THE DISTRICT AND SHALL BE EQUIPPED WITH A SAFETY GRATING FOR FALL PREVENTION.
- 5 - THE DIRECTION OF OPENING OF THE WETWELL AND VALVE VAULT ACCESS COVERS SHALL BE APPROVED BY THE DISTRICT.
- 6 - THE LAYOUT OF ALL LIFT STATION FACILITIES (WETWELL, VALVE VAULT, POWER TRANSFORMER, CONTROL PANEL, BOLLARDS, ETC.) SHALL BE APPROVED BY THE DISTRICT. BOLLARDS SHALL BE INSTALLED IN SLEEVES SO THEY CAN BE REMOVED AS NECESSARY.
- 7 - VICTAULIC FITTINGS MAY BE USED IN PLACE OF THE FABRICATED FITTING. GLUED FITTINGS SHALL NOT BE PERMITTED.

SCALE: NONE

ORIGINAL	
04/29/2019	LBH
REVISIONS	
07/07/2020	LBH

SOUTH DAVIS SEWER DISTRICT

**LIFT STATION
PUMP BYPASS DETAIL**



SHEET:

114-11